



2

KEYANG 2 - CYCLE ENGINE



KY171
KY171-D
KY201
KY201-D



계양전기주식회사
KEYANG ELECTRIC MACHINERY CO., LTD.

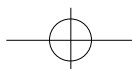



- -
- -

: 080-023-8204()

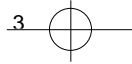

•	4
•	9
•	10
•	11
•	12
•	13
•	14
•	16
•	17
•	19



가

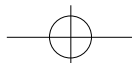



1.

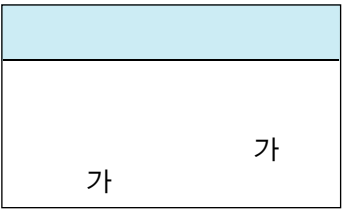
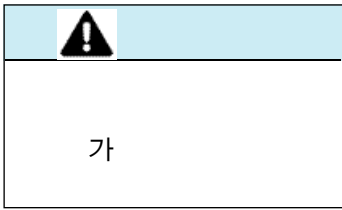
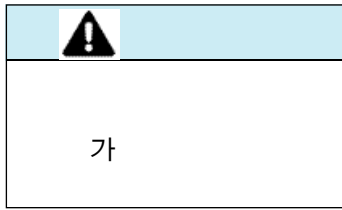

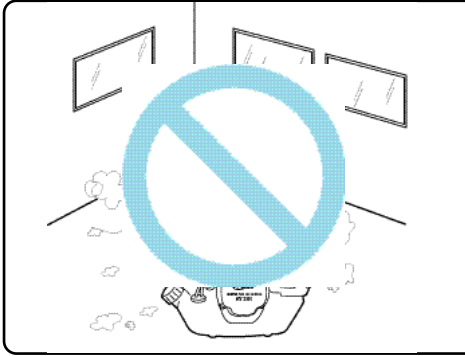

가
가

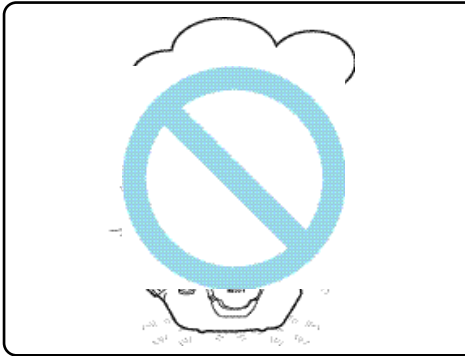

가

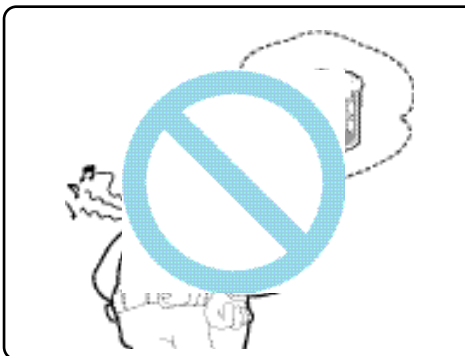

가

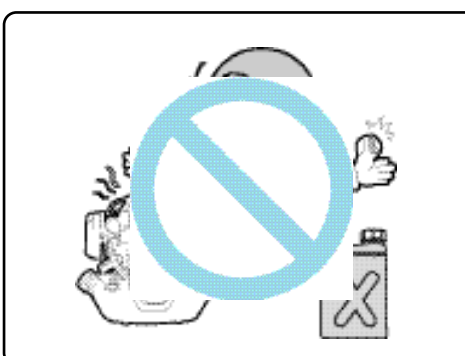

가

	<p>가</p>
---	----------

	<p>가 가</p>
--	----------------

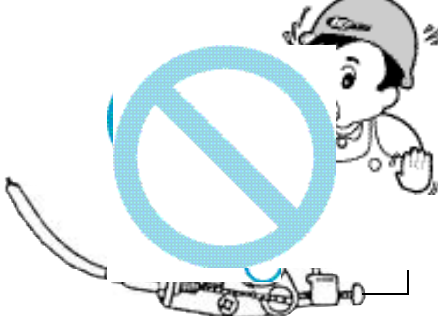
	<p>()</p>
---	------------

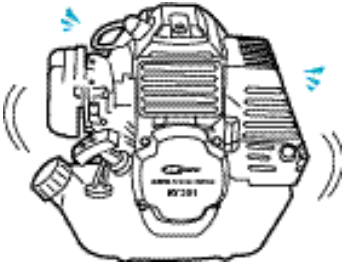
	<p>가 가 가</p>
---	----------------------

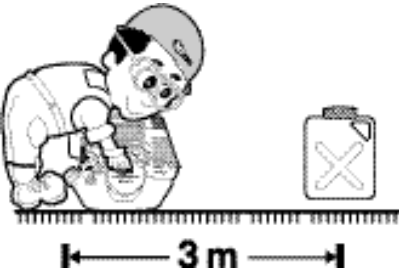

	<p>가</p>
---	----------

	<p>가 3 m 가</p>
--	------------------------

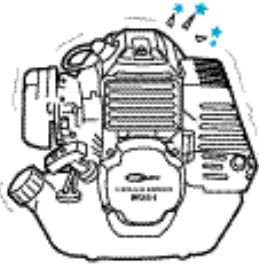
	
---	--

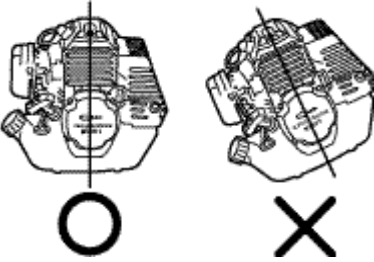
	<p>가 가 가</p>
---	----------------------

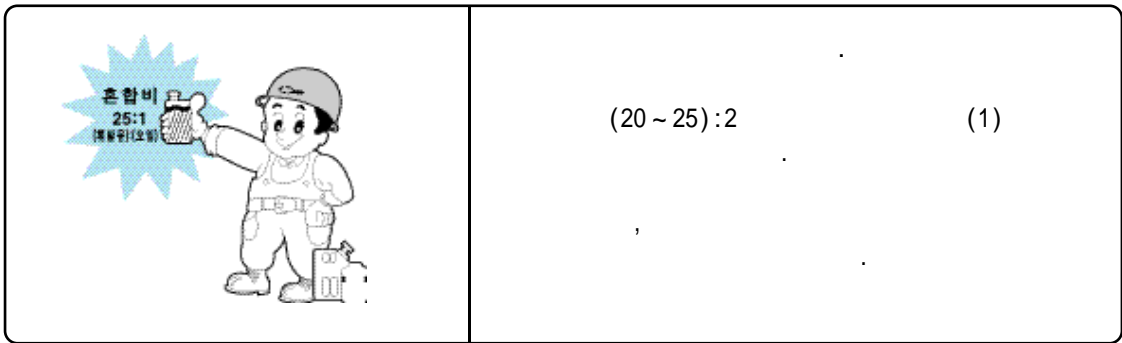
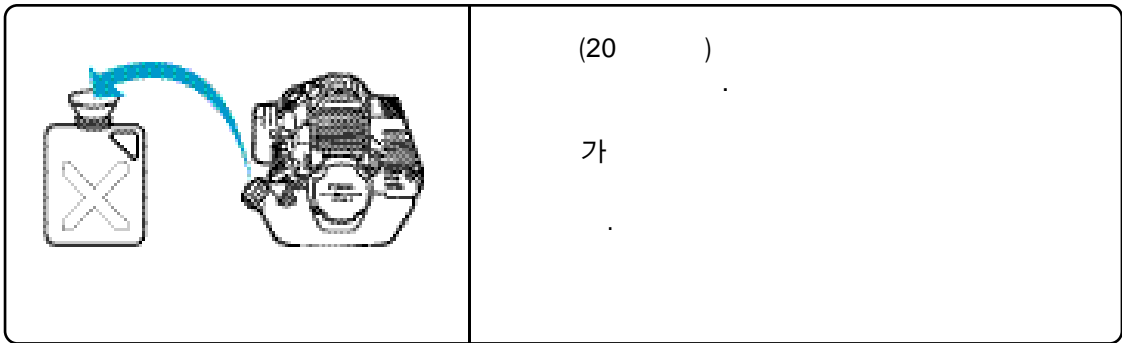
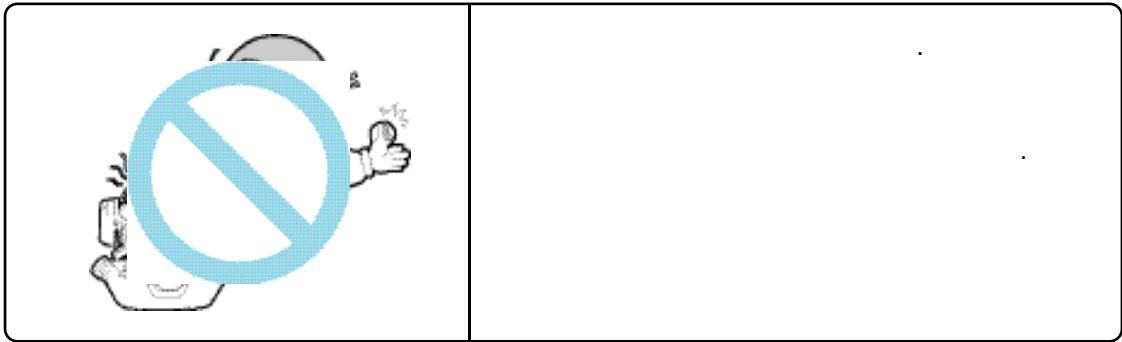
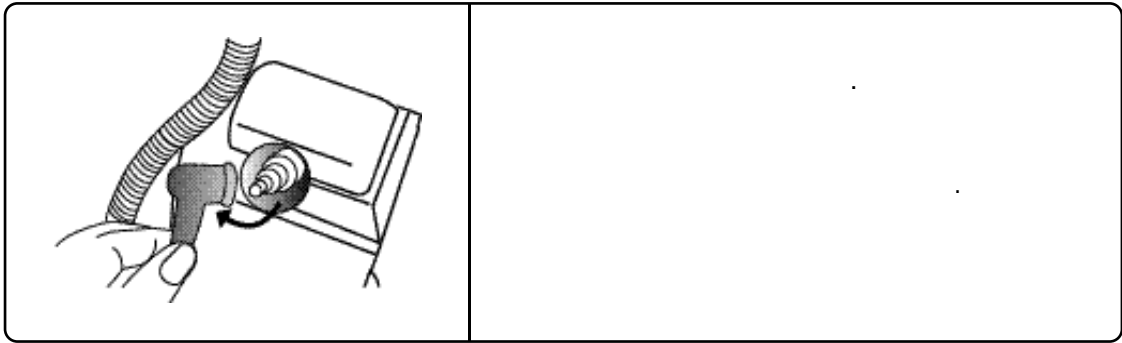

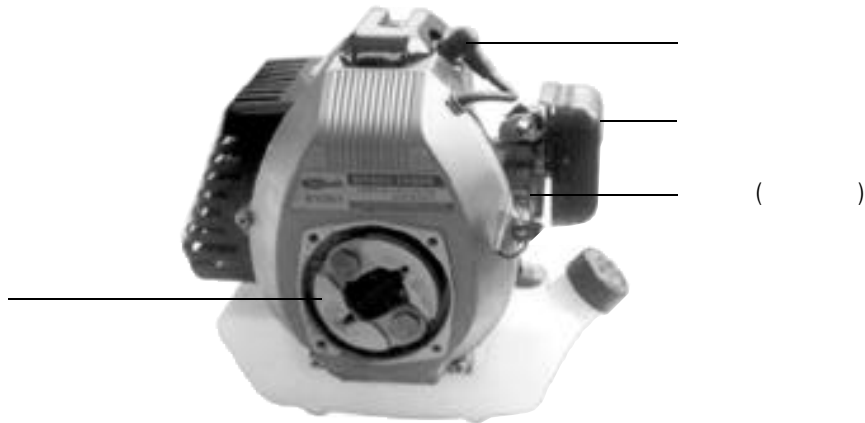
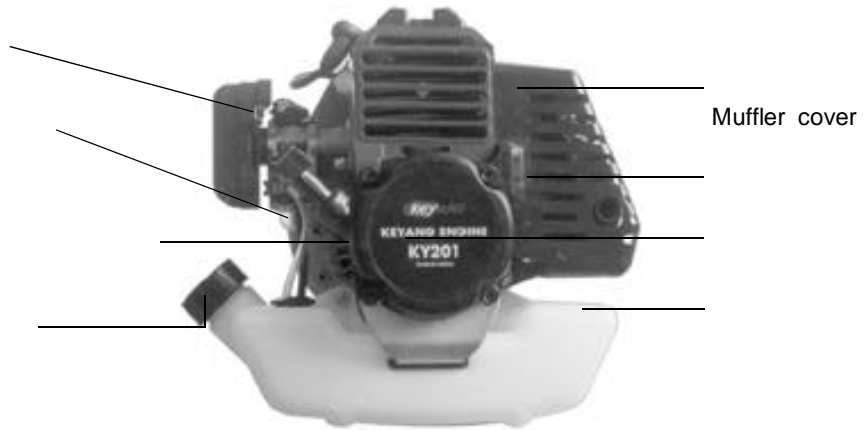

2.

0.5~1mm가

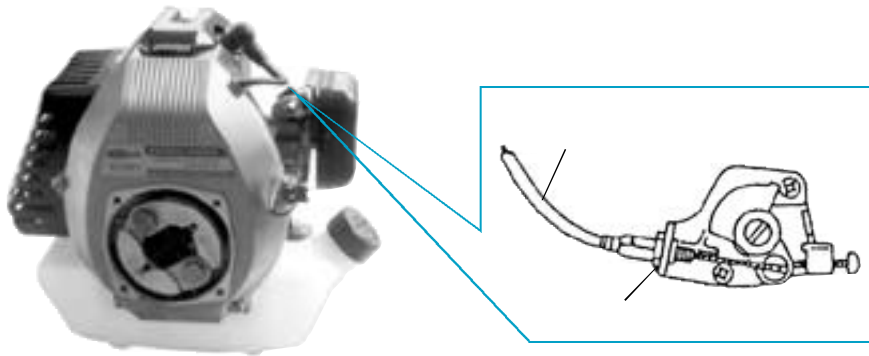



		KY 171	KY 171-D	KY 201	KY 201-D
		2			
	(cc)	32.6		40.6	
	(ps)	1.7		2.0	
		: 2		(20 ~ 25:1)	
	()				0.9
	(kg)	3.1		3.5	3.8

3.



1.

2



 25():1(2)

2.

1.

2. () 10

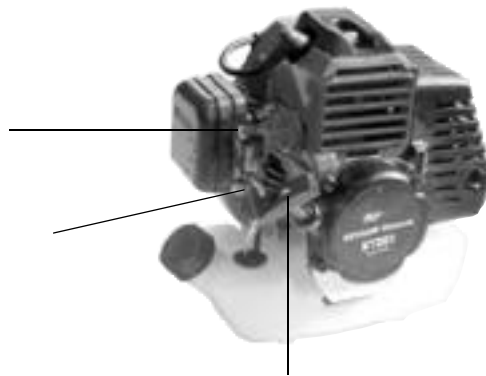

3. 「CLOSE」

4.



3~4

「OPEN」

5.

「OPEN」



1

6.



1.

2.

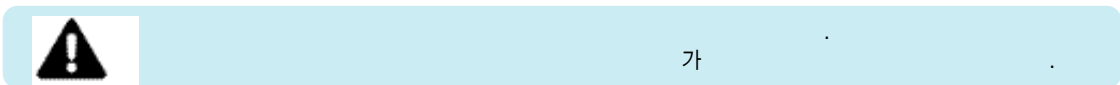

4.



1. 

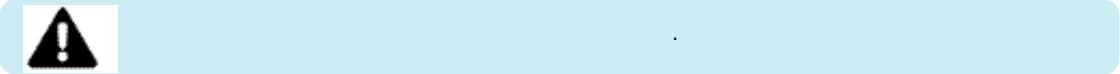

1.

2.

3.

4.

5. 가

가



2. () 

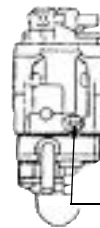
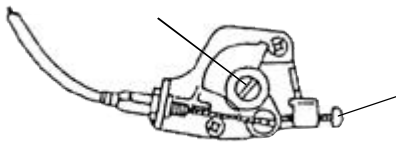

1.

:

가

:

가

2. : 가 . : 가 .

3. : 가 . : 가 .

 () 가 A/S .

3.

1.

		25	50	100

2. : .



3. : 0.6~0.7mm()

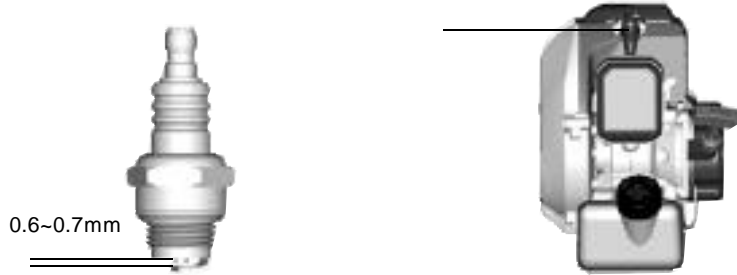

4. :



•

	가 ?	
	가 ?	가
	?	
	가 ?	
	가 ?	
	가 ?	가
	가 가 ?	(가 : =25:1)

 가 가 A/S ()



 **啓洋電機株式会社**
KEYANG ELECTRIC MACHINERY CO., LTD.

TEL: (031) 490-3000, FAX: (031) 490-3019



			KY171, KY171-D, KY201, KY201-D
		NO.	
(/)			1

- 가
- 1 A/S
- 1
- A/S

1.		
2.		()
3.	()	()



계양전기주식회사

KEYANG ELECTRIC MACHINERY CO., LTD.

823-2 TEL: (031)490-3000 FAX: (031)490-3019

- : (02)757-8143 ~ 4 • : (031)490-3022
- : (053)253-8141 • : (051)319-0981 ~ 3
- : (042)632-81413 • : (062)511-5385 ~ 6
- : (033)745-8141

1588-0666	080-023-8204
가	080-545-0989

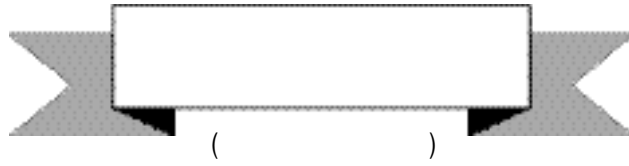

()

()

	KY171, KY171-D, KY201, KY201-D		2CYCLE ENGINE
		1.7PS 2.0PS	

계양전기주식회사



73 4

:
:

()

:
:
:





1588-0666
가

080-023-8204
080-545-0989

KEYANG 계양전기주식회사
KEYANG ELECTRIC MACHINERY CO., LTD.

823-2 TEL: (031)490-3000 FAX: (031)490-3019

- : (02)757-8143 ~ 4 • : (031)490-3022
- : (053)253-8141 • : (051)319-0981 ~ 3
- : (042)632-8141,3 • : (062)511-5385 ~ 6
- : (033)745-8141